

# AKS-INTERNATIONAL (CRANES) LTD

Tel. 01373 813375

Fax: 01373 813576

e-mail [info@aks-cranes.com](mailto:info@aks-cranes.com)

## SPECIFICATION

**WEIGHT 34kg**  
**12v Rechargeable battery**  
**110v or 240v option internal**  
**charger**  
**Battery level gauge and**  
**audible warning**  
**Independent dual vacuum circuits**  
**with audible low vacuum alarm**  
**Manual tilt from horizontal**  
**into vertical**  
**Manual lockable rotation**  
**+/- 90 deg.**  
**Suction cups (4) 305mm dia.**

**P11104**  
**DUAL CIRCUIT**  
**4-IN-LINE**

**SWL 320kg**

**180 degree rotation**  
**And 90 degree tilt**



# AKS-INTERNATIONAL (CRANES) LTD

Tel. 01373 813375

Fax: 01373 813576

e-mail [info@aks-cranes.com](mailto:info@aks-cranes.com)

## SIZES

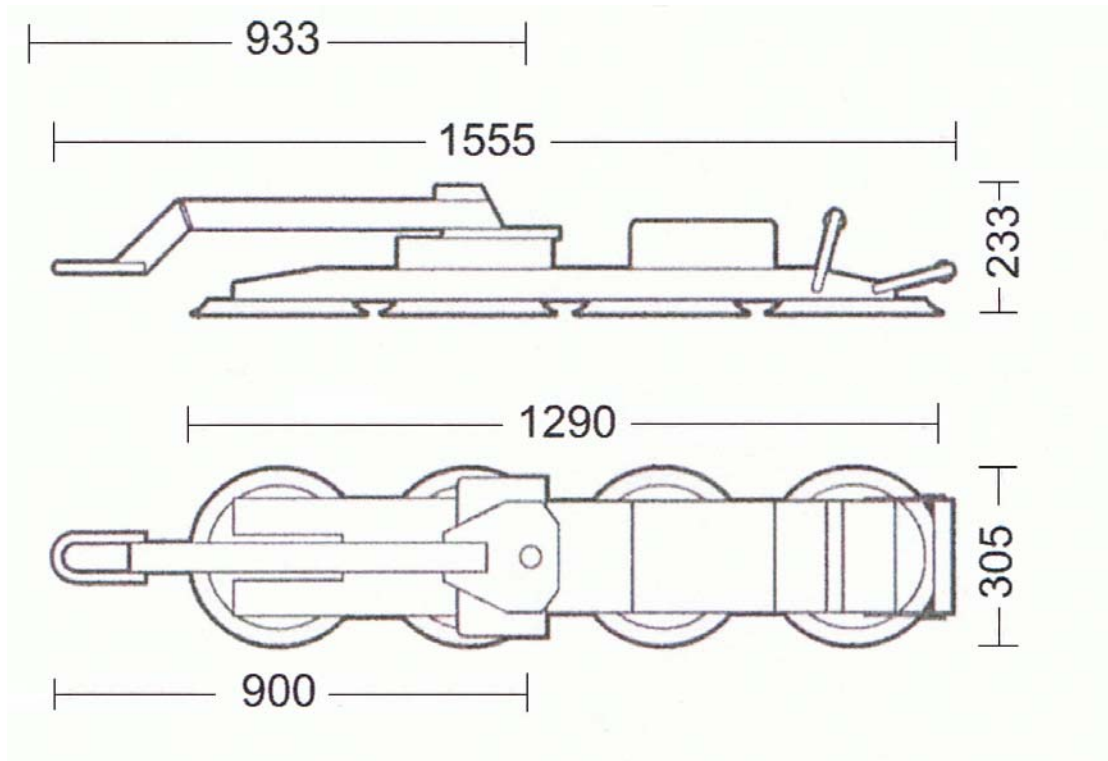

### **P11104 DUAL CIRCUIT 4-IN-LINE**

**SWL 320kg**