

AKS-INTERNATIONAL (CRANES) LTD

Tel. 01373 813375

Fax: 01373 813576

e-mail info@aks-cranes.com

SPECIFICATION

Weight 58kg approx.
12v Rechargeable battery
110v or 240v option internal
charger
Battery level gauge and
audible warning
Independent dual vacuum
circuits with gauges and
audible low vacuum alarm
Manual tilt from horizontal
into vertical
360 deg. Continuous manual
lockable rotation
Suction cups (4) 305mm dia.

MRT 4 DUAL CIRCUIT

With extra frame
configurations with
the 4 additional
arms supplied

SWL 320kg

360 degree continuous rotation

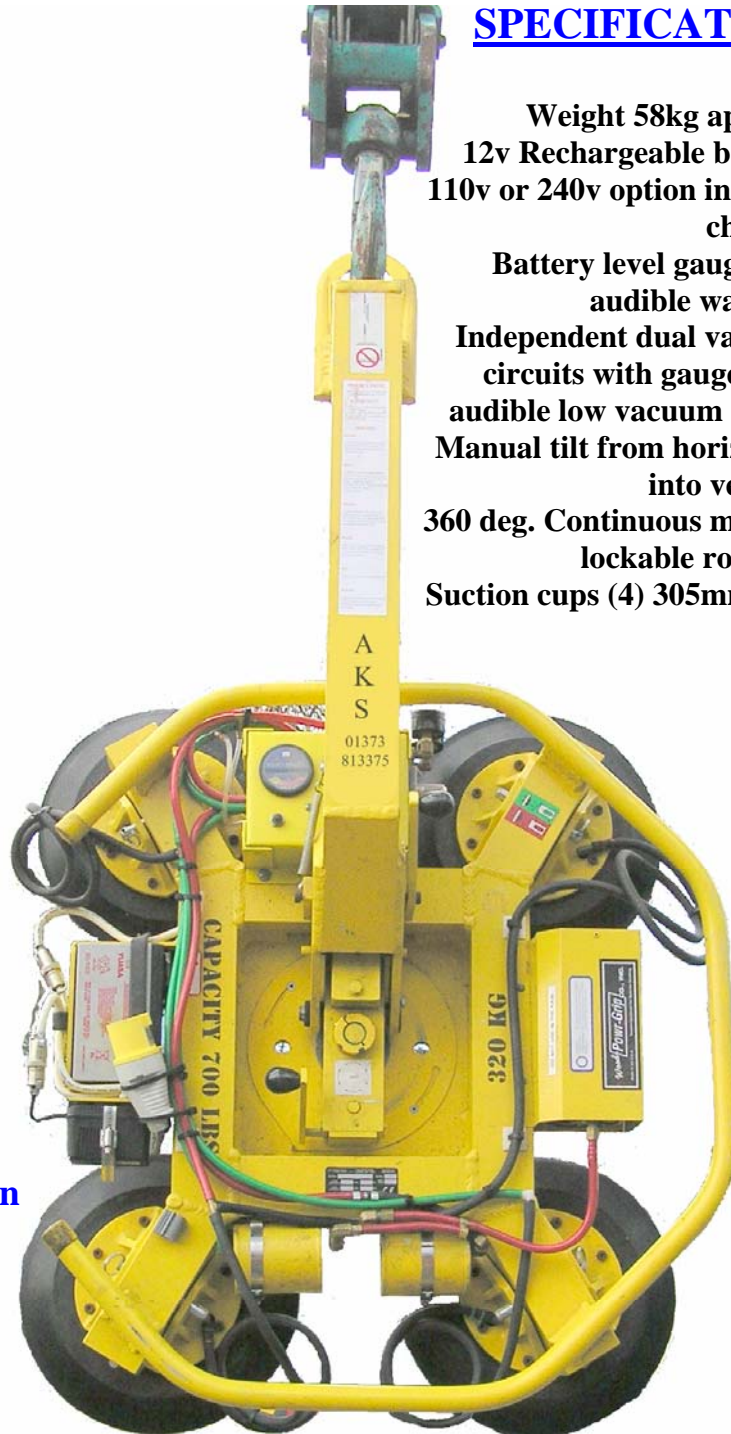

AKS-INTERNATIONAL (CRANES) LTD

Tel. 01373 813375

Fax: 01373 813576

e-mail info@aks-cranes.com

SIZES

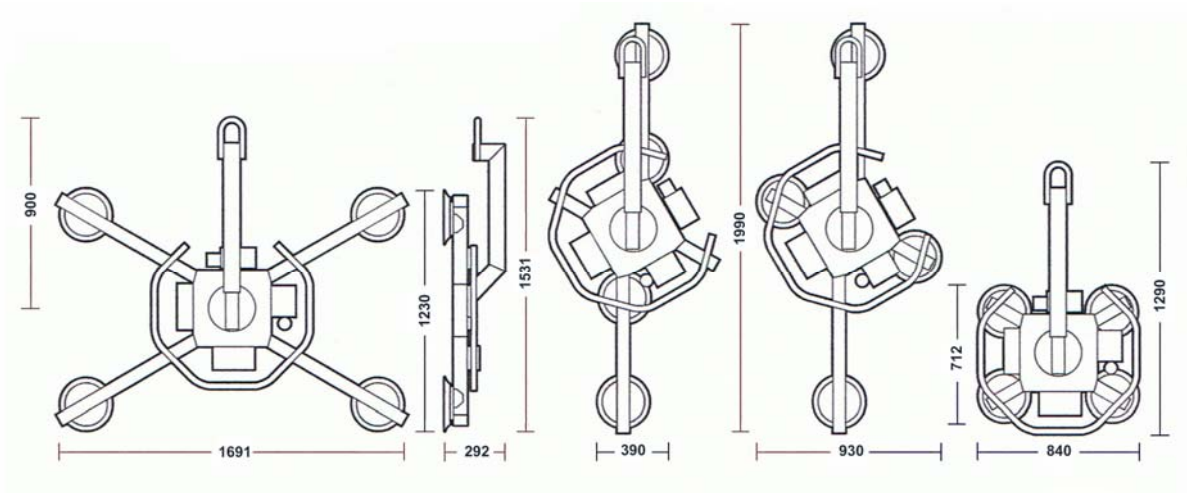

MRT 4 DUAL CIRCUIT

**With extra frame
configurations with
the 4 additional
arms supplied**

SWL 320kg

360 degree continuous rotation